

# RedaHPS

## Horizontal pumping system

### APPLICATIONS

- CO<sub>2</sub> boosting
- Coalbed methane fracturing
- Crude oil boosting and transfer
- Lean amine circulation
- Liquefied and natural gas boosting and transfer
- Manufacturing pressure boosting
- Mine dewatering
- Power fluid boosting for hydraulic lift systems
- Salt dome leaching
- Seawater disposal and waterflooding
- Secondary and tertiary oil recovery projects
- Water injection
- Water disposal

### BENEFITS

- Reduced environmental risk
- Reduced downtime and quick repairs
- Simple, quick reconfiguration of pumps and motors
- Ease of commissioning and piping alignment
- Low maintenance costs
- Minimal vibration-related wear and stress

The RedaHPS\* horizontal pumping system is a multistage centrifugal surface pump that provides up to 1,864 kW [2,500 hp] in a single unit. It is reliable, cost-effective, and flexible enough to be modified in the field. The modular design makes the unit suitable for a wide variety of applications, from simple water injection to more complex refinery services and crude oil transfer. The system's quiet operation makes it appropriate for urban and environmentally sensitive locations.

Prepackaged units are provided as a whole system from a single-source vendor and are delivered pre-assembled to a site. The skid package is typically prewired with instruments and cabling to a central junction box. Intake and discharge flanges and

power hookups are usually the only required connections. When necessary, major components can be exchanged within 2 to 3 h and, with the exception of the motor, do not require realignment before the pump is restarted.

Designed for years of trouble-free service, the RedaHPS series requires no daily maintenance. There are no V-belts or packing to service, and a typical routine maintenance schedule is a quarterly lubricant change and component check. The smooth performance extends equipment life and greatly reduces the chance of leakage from associated piping.

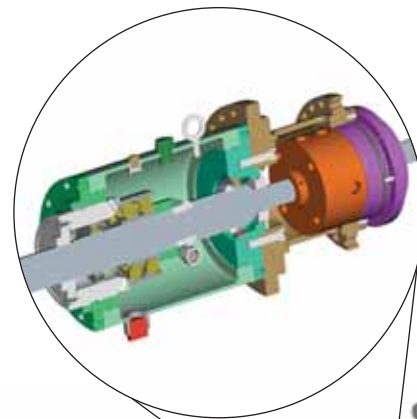

- Thrust chambers
  - Designed for increased reliability, seal support, and mean time between failures
  - Single, double, or triple thrust-bearing designs within one housing
  - Load capacity up to 80,068 N [18,000 lbf]

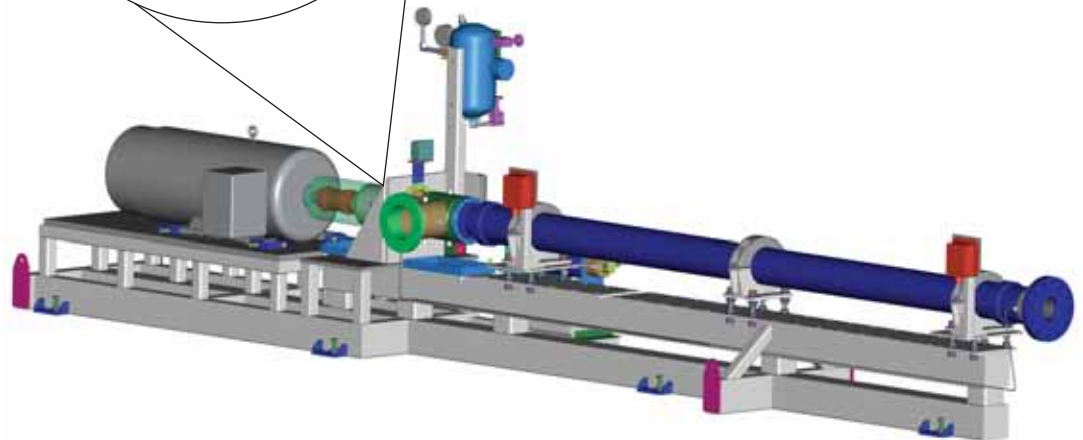

*RedaHPS system with optional hoist facilitates the change-out of modular components.*

## FEATURES

- Seals
  - One mechanical seal on suction pressure side
  - Standard-mount single, double, and tandem cartridge seals
  - API 682 seals and flush plans available
- Skid
  - Adjustable clamp and motor mount locations
  - Rigid box steel frame construction
  - Standard or custom skid designs
  - Intake that orients 270° in 45° increments

## Performance Specifications

Capacity, m <sup>3</sup> /min [galUS/min]	0.15 to 9.5 [40 to 2,500]
Discharge pressure, kPa [psi]	Up to 45,850 [6,650]
Suction pressure, <sup>†</sup> kPa [psi]	Up to 27,579 [4,000]
Temperature range, <sup>‡</sup> degC [degF]	-29 to 138 [-20 to 280]
Power (single skid), kW [hp]	Up to 1,864 [2,500]
Testing capability, kW [hp]	Up to 1,864 [2,500]

<sup>†</sup> Fluid dependent.

<sup>‡</sup> Modifications required.

## Material Specifications

Impellers and diffusers	Ni-Resist™, 5530 alloy, coatings as required
Shafts	17-4 PH, Monel®, and Inconel®
Intake and discharge	Carbon steel and 316 stainless steel
Sleeve bearings	Ni-Resist, ceramic, tungsten carbide, silicon carbide, and Graphalloy®
Flanges	ANSI 150 to 2,500 RF and RTJ

[www.slb.com/redahps](http://www.slb.com/redahps)

**Schlumberger**